

CONFIGURATION

TEST TOOL

- IOMeter server I/O performance storage measurement tool

SERVER MACHINE

- Dell PowerEdge R630
- 64 GB Memory
- Intel Xeon E5-2640 2.60 GHz processor

STORAGE

- 16Gb NetApp EF560
- Toshiba 12Gb SAS SSDs

OPERATING PLATFORM

- Windows 2012 R2

CONNECTION

- ATTO Celerity™ FC-322E
- QLogic QLE2742
- Brocade G620 32Gb Switch
- Windows MPIO
- IO transfer size 128KB

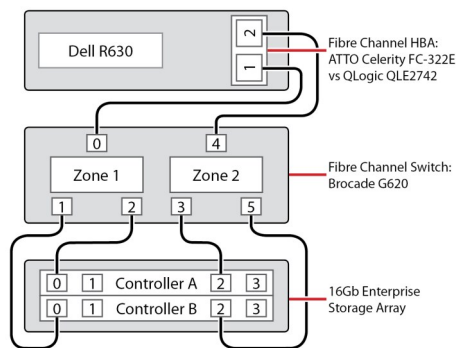

OVERVIEW

Performance testing in a Windows® server environment was conducted to obtain comparative benchmarks of the ATTO Celerity™ 32Gb dual-port host bus adapter (HBA) and QLogic® 32Gb dual-port HBA. IOMeter measurement tool was used to capture the data presented in this comparison testing. Both HBAs were tested in 32 Gb/s Fibre Channel mode in the PCIe 3.0 slot of a Dell® PowerEdge R630 server with an Intel® Xeon® E5-2640 2.60 GHz processor running Windows 2012 R2. The benchmarks were performed at file transfer sizes ranging from 1MB to 16MB. These file sizes are common in large block streaming data environments such as Media and Entertainment, Oil and Gas and Medical Imaging.

RESULTS

Across the full range of file transfer sizes tested, ATTO outperformed the competition in a Windows server environment by a sizable margin.

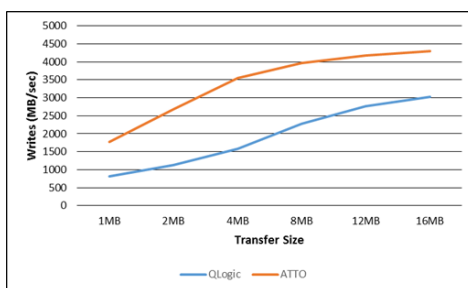

Figure 1 - ATTO 32Gb/s HBA offer up to **137% better writes** than QLogic 32Gb/s HBA (100% Writes)

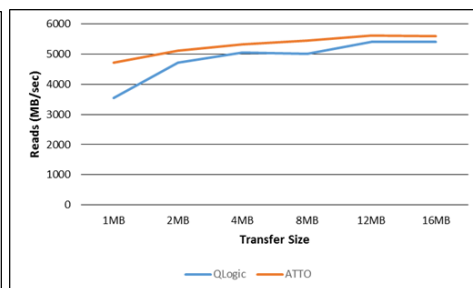

Figure 2 - ATTO 32 Gb/s HBA offer up to **33% better reads** than QLogic 32Gb/s HBA (100% Reads)

SUMMARY

For nearly 30 years, ATTO, Inc. has been a global leader in storage and network connectivity and infrastructure solutions for data-intensive computing environments. ATTO Celerity Fibre Channel HBAs available in 32Gb, 16Gb and 8Gb speeds all feature Advanced Data Streaming™ technology which provides the highest throughput speeds, very low latency and the most powerful connection to enterprise class storage. Designed with the most demanding workgroup workflows in mind, Celerity HBAs also feature the world's only MultiPath Director™ driver that allows both workstations and servers in heterogeneous environments to connect directly to storage while providing load balancing and path failover protection.

Whether you require blazing speed and low latency to edit the latest high resolution film or support high-performance computing applications connected to all-flash arrays in your data center, ATTO Fibre Channel HBAs deliver the performance, reliability and resiliency for the highest level of service .