

Comparison of Native Fibre Channel or Ethernet Tape and SAS Tape Connected to an accelerated XstreamCORE® Controller

White Paper



Introduction

IT Managers may approach backing up Storage Area Networks (SANs) with the idea of purchasing native Fibre Channel or Ethernet tape drives or libraries. This paper examines the technical and economic considerations of implementing an alternative solution for SAN backup and archive; a Fibre Channel-to-SAS, or Ethernet-to-SAS bridging device powering SAS tape drives or libraries. Considerations of which solution to implement will be identified and the benefits of each will be compared on the basis of performance, availability, connectivity, manageability, intelligence and cost.

Although the native Fibre Channel or Ethernet tape options may appear to be less complicated, bridging devices utilizing SAS tape drives, such as an ATTO XstreamCORE®, provides significant advantages.

Native Fibre Channel Tape Implementation

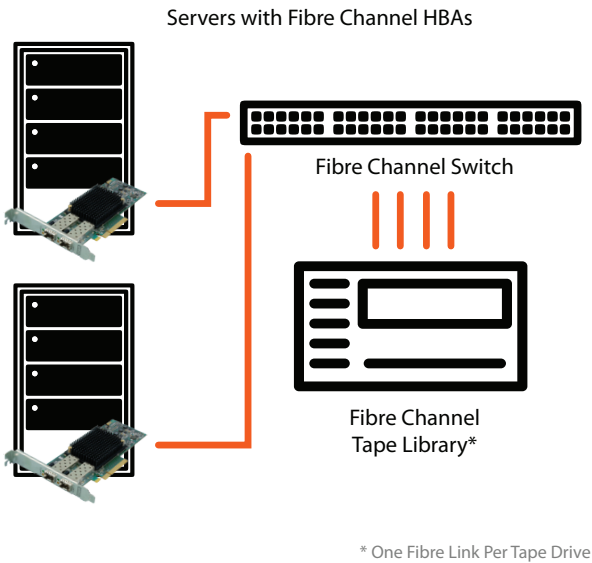

Fibre-to-SAS Tape Implementation

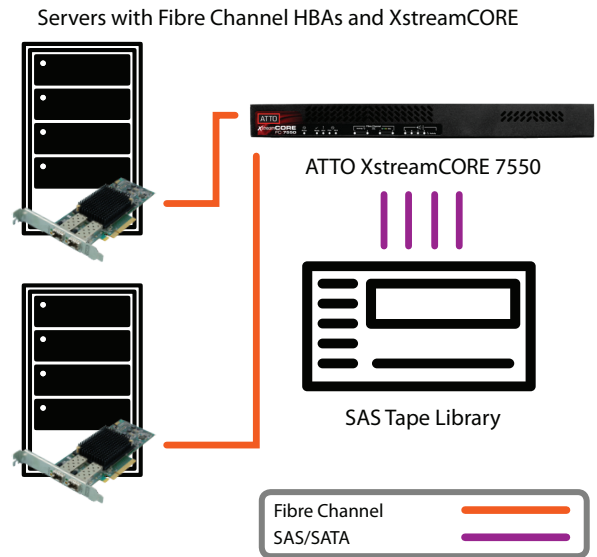

Ethernet drive options are very limited and offer a large pipe that is bottlenecked by the drive speed. Using an Ethernet-to-SAS bridge with standard LTO SAS tape drives such as the ATTO XstreamCORE ET 8200 is a more cost effective and efficient model.

Native Ethernet Tape Implementation

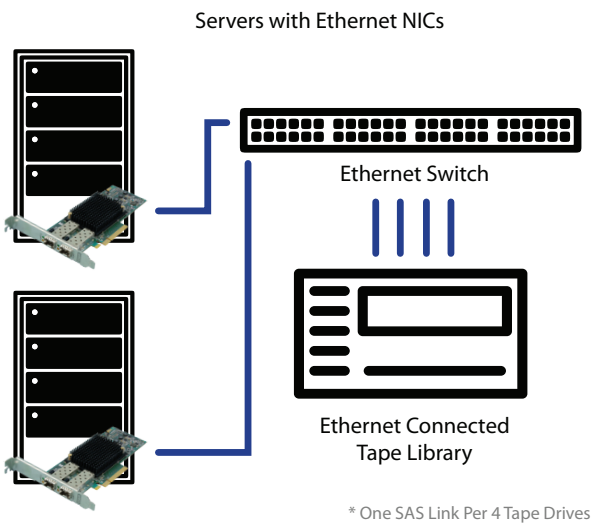

Ethernet-to-SAS Tape Implementation

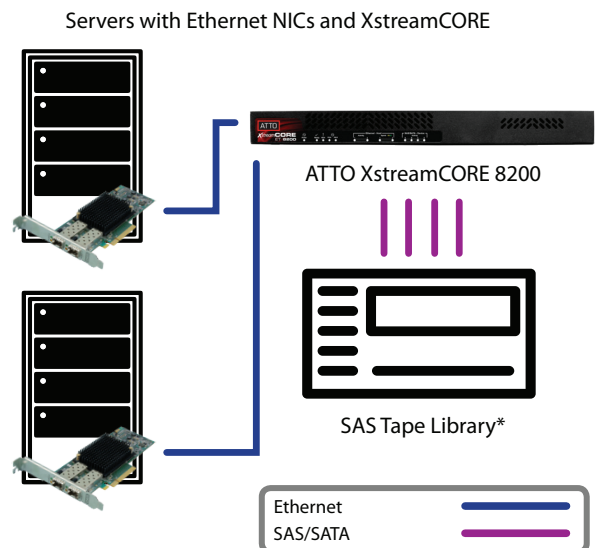

Data Center Ready

The explosion of Big Data and the need to store critical digital content at the petabyte level and beyond are forcing organizations to look beyond traditional storage solutions. As tape capacities grow, new tape technologies are continuing to emerge to help solve today's growing data needs. Tape is quickly becoming the de facto standard for Big Data storage solutions, and new tape drive densities are pushing the archive in new directions. According to Gartner tape is in heavy use for enterprise backup with 78% of companies polled use tape in their data center. Data rates are doubling every two years and Enterprises expect to manage 50x more data and files and expect growth to be over 75x more data in the next decade. With lower energy usage and maintenance LTO tape costs 15x less than SATA disk for long term archival making it the ideal medium for backup and archival of data for corporate or regulatory compliance purposes.

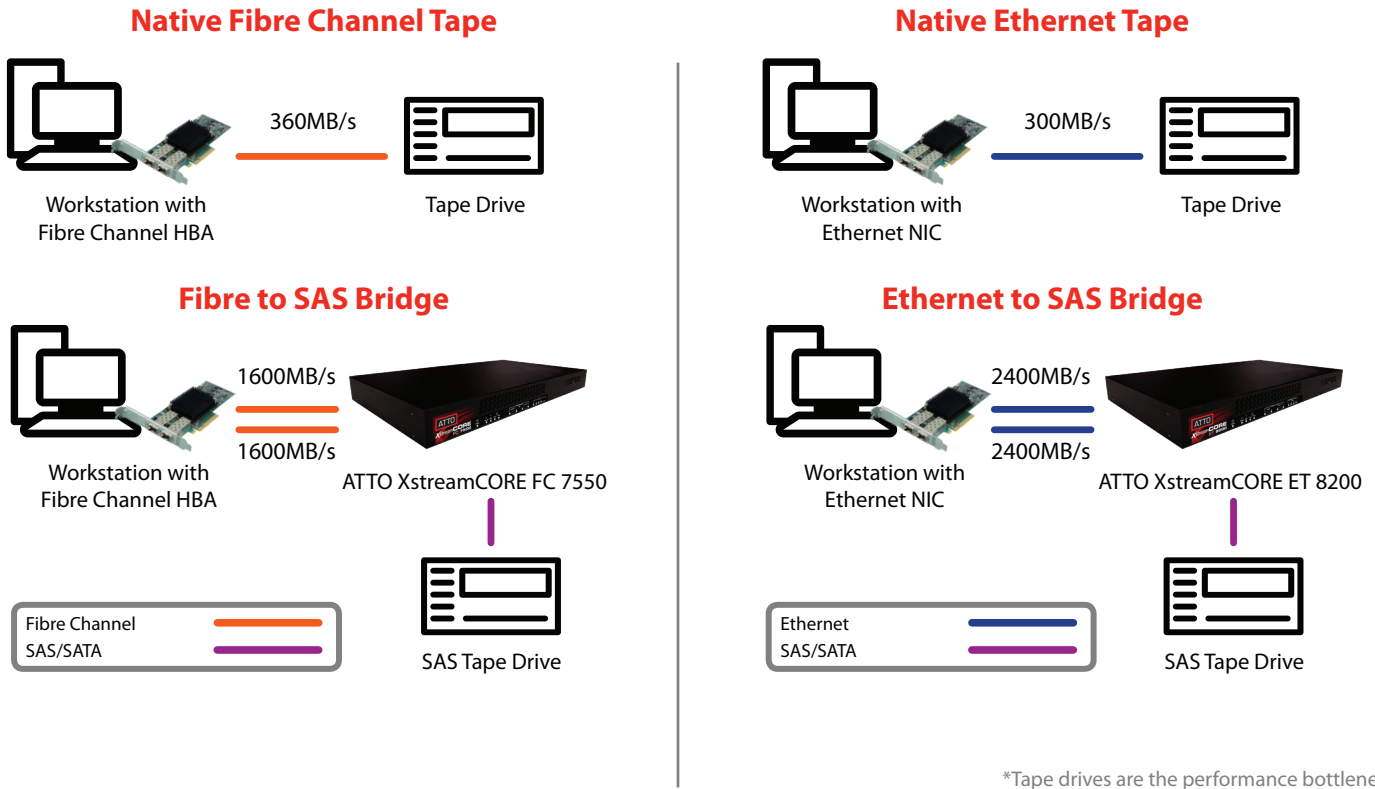

Performance

There is a common misconception that native Fibre Channel or Ethernet devices can outperform SAS drives. The reality is that the type of interface used by the drive does not change its ability to write or read data to tape. Tape performance is a function of how fast the drive can move data from its input buffers to the media, not the speed of the interface itself. So the fact that an 8Gb Fibre Channel LTO drive or an Ethernet 10Gb or 25Gb drive has a faster interface than a 6Gb SAS drive never comes into play.

Regardless, the task of using a backup application to write a block of data to tape, even compressed, will not reach maximum performance. Most applications only use one outstanding command at a time and usually only send 64K of data in each block. The ATTO XstreamCORE® actually increases performance by utilizing its SpeedWrite™ function. The controller will buffer up write commands as well as data to effectively allow more than one command to be outstanding at any point in time. The result is that a host can issue new write commands to an XstreamCORE SAS target in faster succession than is possible with standard architecture. The path between the host and the controller is continuously filled with data, reducing the latency associated with pauses. This leads to 25% better performance over direct-attached tape drives.

The controller also provides value in that it can balance the performance to multiple drives concurrently.

Server to Native Fibre Channel or Ethernet Tape Commands

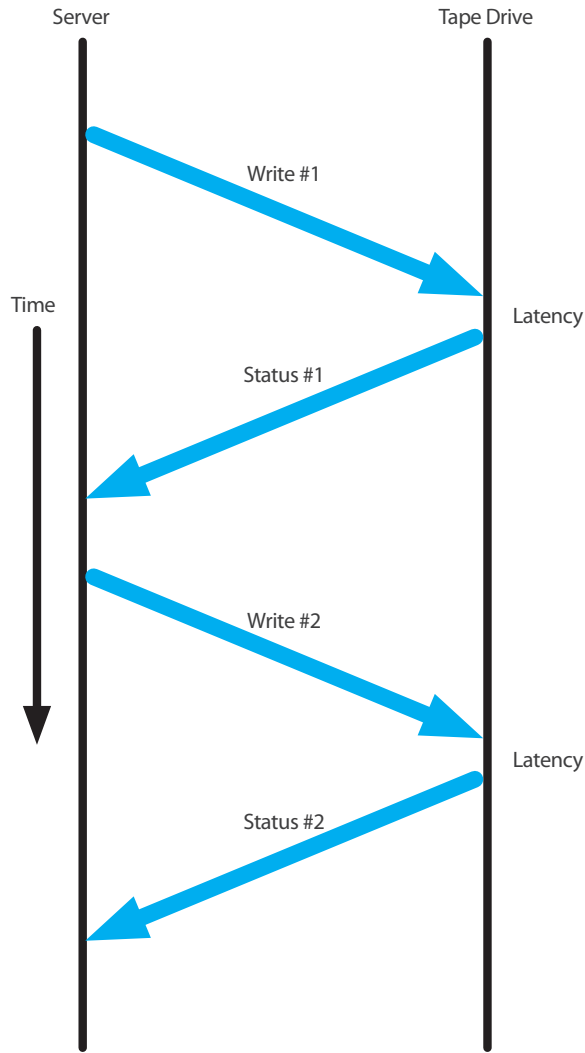

Tape Commands using SpeedWrite™ in the XstreamCORE®

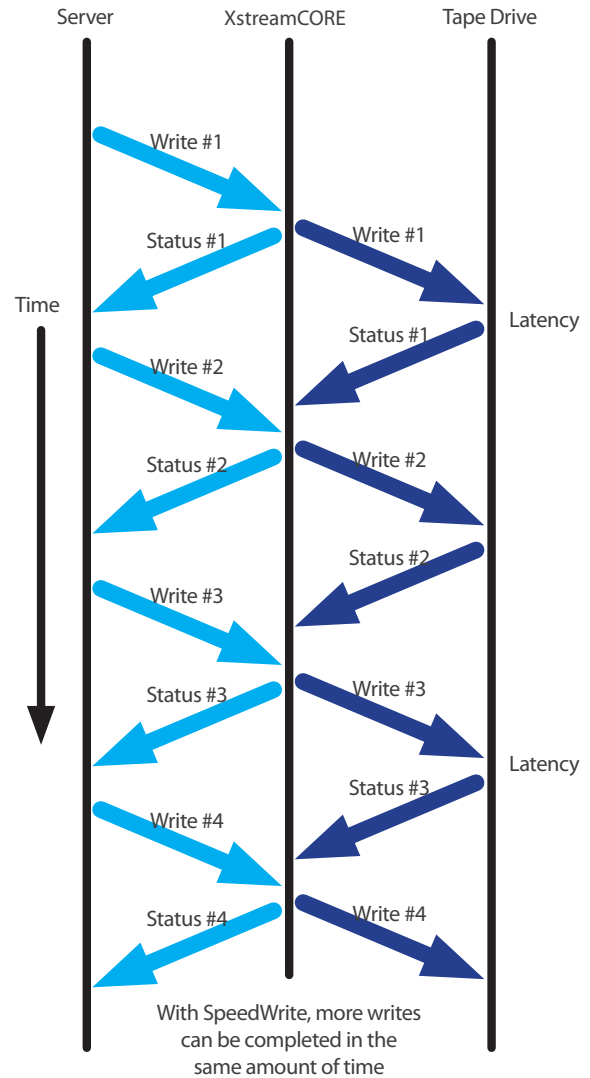

Availability

End users tend to lean toward native Fibre Channel tape drives because they feel they have the ability to design for multiple redundant paths into the drives which will increase the probability that unattended backups will complete overnight. Fibre Channel SANs do offer an easy way to allow multiple connections and redundant paths between servers and tape drives. Some native Fibre drives even come with two independent ports.

What customers do not realize is that they can get a similar level of redundant paths using an ATTO XstreamCORE® with SAS tape drives. The front end of the controller has two or four independent Fibre Channel ports or two independent Ethernet ports. Each SAS tape drive can be mapped to all ports providing two to four independent paths for each drive.

By assigning a standby port, the XstreamCORE increases data reliability through available redundant paths. Should an error occur with one of the active ports, data can be automatically re-routed to the standby port. This provides additional data redundancy and improved disaster recovery for backup systems.

The controller itself does present a single point of failure (as does a single Fabric switch) but the failure rate of this device compared to the tape drives, media, cables, optical transceivers and everything else in the configuration is relatively low.

Manageability

ATTO XstreamCORE® products allow for consolidated management of all drives and the media changer in one place using the ATTO XstreamVIEW™ System Manager browser-based remote monitoring and management GUI. This tool is supplied with every controller at no additional cost and includes such features as SNMP monitoring capabilities, extra large advanced event and error logging with SNTP-based time stamp recording, link up/down monitoring; SAS drive health monitoring, temperature and voltage monitoring and many more easy-to-use configuration capabilities. In addition, the XstreamCORE allows for in-field troubleshooting and diagnostics via a built-in trace log that provides bus analyzer-like capabilities. A key total cost of ownership factor to consider is how long it takes to identify and resolve an issue once a hardware failure occurs. The troubleshooting assist capabilities provided in the XstreamCORE products can reduce down time considerably.

The XstreamCORE can also communicate in-band over the Fibre Channel or Ethernet link to provide monitoring and management for customers who already have management tools in place.

Intelligence

Fabric SANs are one of the leading methods to implement cloud-based, virtualized server and other high-end enterprise server/storage based environments and customers need to use special purpose-built products to manage these installs. Adding intelligence is the key to adding value to the network.

The intelligence the ATTO XstreamCORE® products add to managing the backup environment is one of the most significant benefits over native Fibre Channel or Ethernet tape. Some of the benefits provided by the controller include:

- Mapping. The XstreamCORE allows administrators to map specific drives to one or any Fibre Channel or Ethernet ports, as well as to one or more host computers. Controlled access and security can easily be managed from a single point in the controller.
- Fibre Channel Tape Error Recovery. The XstreamCORE supports advanced error level recovery algorithms that increase the probability of backups completing. Native Fibre drives do not have this capability.
- SNMP Traps. The XstreamCORE supports standardized SNMP traps to deliver systems administrators a quick and concise synopsis of the Tape Library system's status via the Ethernet management port.
- Simultaneous iSER and iSCSI support on Ethernet XstreamCORE models allow for compatibility with the widely installed iSCSI protocol and the high speed iSER protocol.

Cost

System Administrators need to consider the entire cost of the solution when comparing native Fibre or Ethernet Tape to a Fibre Channel-to-SAS Bridge. On average, a native Fibre Channel tape drive costs around \$750 more than the same drive with a SAS interface. Each native drive requires a dedicated Fibre Channel switch port. At approximately \$500 per port this can add up quickly. The need for additional Fibre Channel cables and optical transceivers also results in a considerably higher native Fibre Tape solution cost.

Consider the following real life example. A user with a tape library that houses four LTO drives wants to create a managed backup solution that runs from two servers at the best possible performance.

Native Fibre Channel Tape

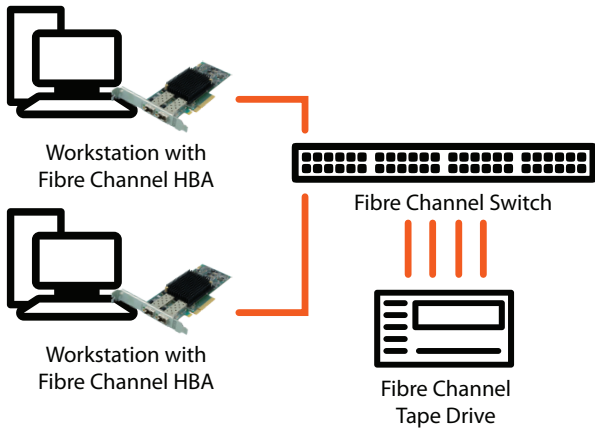

Native Ethernet Tape

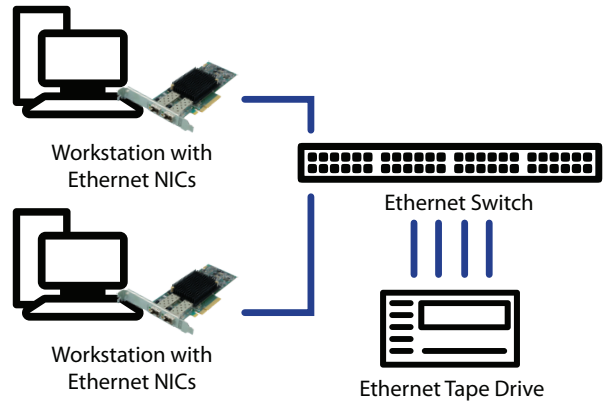

Fibre to SAS Bridge

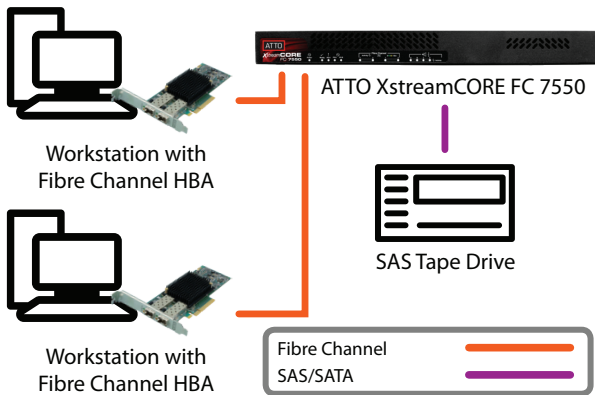

Ethernet to SAS Bridge

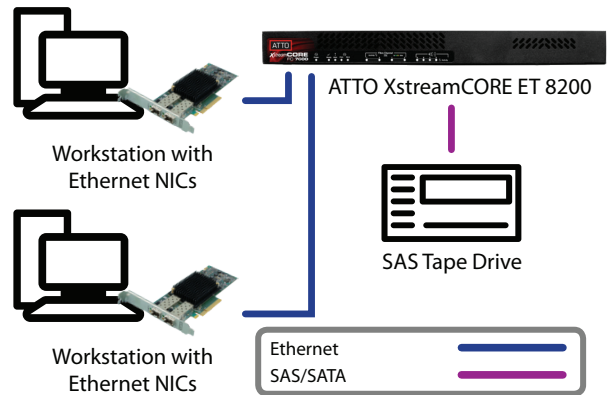

Estimated Cost of Differential Analysis

Item Required	Native FC Tape	XstreamCORE FC 7550	Native Ethernet Tape	XstreamCORE ET 8200T
Tape library with media changer	Same	Same	Same	Same
Two (2) Servers	Same	Same	Same	Same
Two (2) Fibre Channel Adapters	Same	Same	N/A	N/A
Two (2) Ethernet NICs	N/A	N/A	Same	Same
Difference in Tape Drive Cost	12 @+\$750 = \$9,000	\$0	12 @+\$1,500 = \$12,000	\$0
8 Port Switch with transceivers	\$13,000	\$0	\$8,000	\$0
XstreamCORE	\$0	\$12,995	\$0	\$10,995
Cables	14 @ \$75 = \$1,050	2 @ \$75 = \$150	14 @ \$50 = \$700	2 @ \$75 = \$150
SAS Cables	\$0	4 @ \$100 = \$400	\$0	4 @ \$100 = \$400
Total on Differences:	\$23,050	\$13,545	\$26,700	\$11,545

Retail cost of 12 native Fibre Channel tape drives is about 79% more than using SAS tape drives with a Fibre Channel to SAS XstreamCORE. While 12 native Ethernet drives is about 70% more expensive than using SAS tape drives with an Ethernet to SAS XstreamCORE.