

# Developing an OEM Partnership with ATTO Technology, Inc.



**ATTO**

The Power Behind the Storage

## **Deliver on your Design's Performance Cost and Timeline Goals**

Developing a product that depends on network and/or storage connectivity always presents challenges regardless of whether it's new, a product upgrade or a refresh. What technical hurdles are you willing to overcome? At what cost? Can you make it all happen on time?

This is especially true when the design proposal requires technology outside of your core expertise. However, you can overcome these challenges by choosing the right connectivity partner.

Partnering with ATTO will save you development time and costs while addressing the technical challenges of connectivity - all at the same time.

We work collaboratively with our partners from day one to design and manufacture their solutions. We operate within your time frame and budget, sharing our intellectual property and 30 years of engineering expertise.

ATTO can help fast track your product's development, differentiate your product and create value for your customers. Read on to see how we can do this for you.

### **About ATTO**

For 35 years, ATTO Technology, Inc. has been a global leader across the IT and data intensive environments, specializing in storage and network connectivity and infrastructure solutions for the most data-intensive computing environments. ATTO works with partners to deliver end-to-end solutions to better store, manage and deliver data. Working as an extension of customer's design teams, ATTO manufactures HBAs and RAID adapters, network adapters, storage bridging controllers, DRAM-based storage appliances and software. ATTO solutions provide a high level of connectivity to all storage interfaces, including Fibre Channel, SAS, SATA, iSCSI, Ethernet, NVMe, NVMeOF and Thunderbolt™. ATTO is the Power Behind the Storage.

*All trademarks, trade names, service marks and logos referenced herein belong to their respective companies.*



**The Power Behind the Storage**



## **Accelerated Time-to-Market**

- Phase-gate Protect management process for accelerating product development
- Streamlined, well-defined, collaborative workflows

## **Differentiated Solutions**

- Engineering team acts as an extension of the customer's design team
- Proprietary technologies for data delivery and protection
- Multiple form factors to choose from for easy integration
- Unique technology feature set

## **Unique Development Partner**

- Broadest portfolio of technologies, designed to work together
- Customized program capabilities
- Industry renowned for working closely with our partners from start to finish
- Repair and warranty service directly through ATTO

# Partnering with ATTO Puts You in Good Company

A global technology company, ATTO has been designing and partnering with the world's top tier Original Equipment Manufacturers for 35 years. Whether or not you've heard of ATTO, our products are installed throughout the world powering the network connections millions rely upon.

Apple, EMC, NetApp, Hewlett-Packard, Harris Corp., Grass Valley, Quantum, Avid Technology, Overland Storage, NEC, Unisys, and many more have relied on ATTO for storage and network connectivity solutions. Certified by the world's top tier storage and compute companies, our work stands on a rock-solid foundation.

ATTO has a thorough background in engineering cutting-edge computer hardware, founded on our industry developments like the first SCSI-based SSD and the first enterprise class ATA-based array. To this day, no one has more network storage connectivity design and engineering experience than we do.

Technical leadership and a history of product innovation, strong financial resources, proven longevity, global distribution capabilities, and a track record of on-time project delivery are among the many distinctions ATTO brings to the table.



## Accelerating Performance for Enterprise & Cloud Storage Applications

### Infrastructure Solutions for the Demands of Big Data

Big Data, cloud computing, audio and video streaming, and mobile broadband internet connectivity continues to grow at an accelerating rate. The sheer volume of data poses many technical challenges on today's modern data center. Moving such massive data around the data center requires a robust infrastructure that is capable of handling high bandwidth data delivery to and from storage endpoints.

#### Challenges:

- Big data has caused an increase in CPU utilization and impacts overall application performance

#### Featured Products:

- ATTO FastFrame™ 10/25/40/50/100Gb Smart Ethernet Adapters
- ATTO Celerity™ 32 and 16Gb Gen 6 Fibre Channel HBAs

#### Solution Benefits:

- Reduced CapEx & OpEx
- RoCE to accelerate hyperscale & cloud workloads without constraint
- Integrated centralized management and monitoring
- Line-rate and near line-rate performance
- Built-in latency management
- Improved TCO

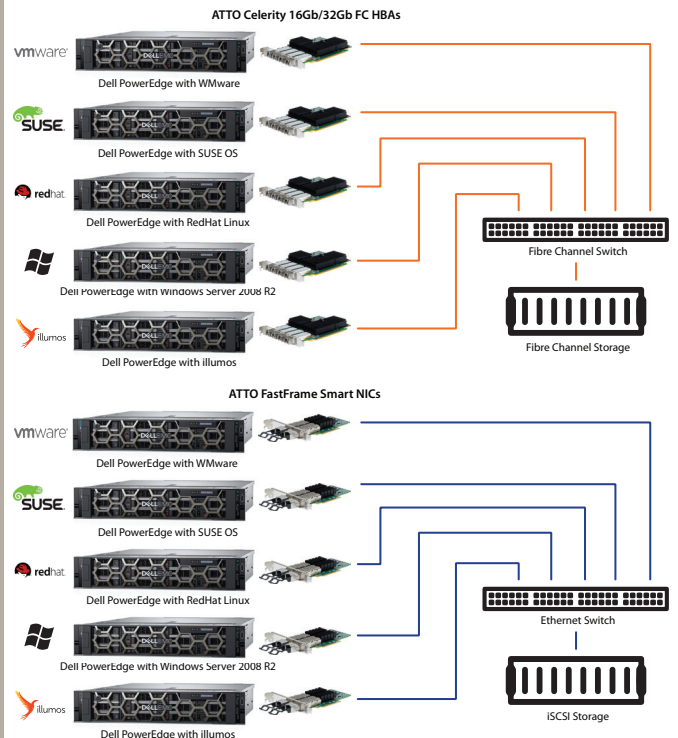

## Extensive OEM Support Capabilities

Partnering with ATTO provides you an exceptional level of expertise, which you can take advantage of the moment you are handed the product specifications. Our commitment to the process is so thorough, ATTO engineers become an extension of your development team.

Our industry leading technology differentiates your product and provides more features and capabilities than competing options. With full customization capabilities, we can design a solution tuned to work exactly as you need and supply whatever quantities necessary.

As an OEM supplier we are able to dramatically accelerate time to market for any product that depends on storage and network connectivity. ATTO can mobilize dedicated design, test, and support teams who are flexible, efficient, and able to turn on a dime when the situation requires.

After the design is complete, you can expect your components will arrive on time and within budget. ATTO has full manufacturing capabilities which range from small semi-custom to large volume programs. ATTO is certified to be fully ISO 9001:2015 compliant, so every step is controlled and documented for quality.

### ATTO's expertise in storage connectivity covers many areas which you can leverage for your design:

- Optimized development for a wide range of operating systems including Linux, Windows®, macOS®, FreeBSD®, illumos™, VMware® and more.
- Expertise in Fibre Channel SANs, Ethernet networks, direct-attached SAS/SATA and new, emerging FC-NVMe and NVMe over Fabrics.
- Fibre Channel bridges, storage controller software and ATTO's own RAID software stack.
- Host Bus, network, RAID and Thunderbolt adapters.

## Accelerating Software Defined Storage Implementation

### Reduce Costs and Increase Performance

Software Defined Storage (SDS) provides a solution to many of the current challenges posed by the changing IT landscape by combining the scalability of the Cloud with the lower costs of standard servers. SDS make storing data, managing data flow and breaking down data siloes easier.

#### Challenges:

- Large and/or complex workloads
- Legacy data storage
- IT budget constraints/cost management
- Geographically dispersed storage infrastructure
- Provisioning multiple storage systems

#### Featured Products:

ATTO offers high performance, reliable storage controller and Fibre Channel products and solutions for the implementation of software defined storage.

- ATTO XstreamCORE™ Fibre Channel to SAS/SATA storage controllers

#### Solution Benefits:

- Integrates with Software Defined Storage to add storage services and features
- Adds Enterprise SAN and Management capabilities to off-the-shelf SAS SSD Flash & HDD JBODs
- Creates high performance, low latency shared storage without the need for expensive all-flash or hybrid storage arrays
- Allows IT Administrators to map servers and clients to specific LUNs
- Scales up with off-the-shelf storage or client/server access as needed

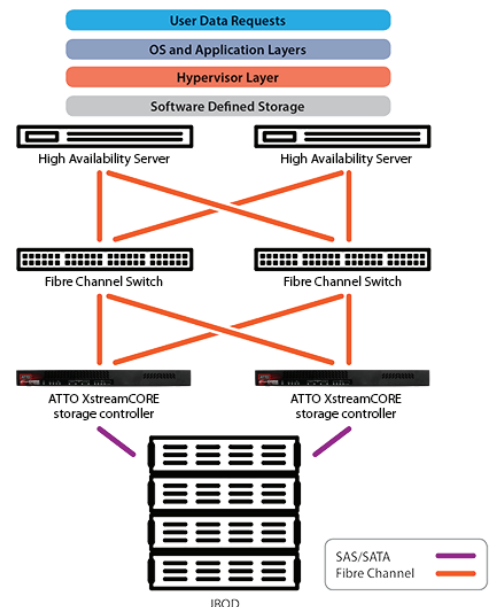

# Success and Survival in the Marketplace Means Choosing the Right Partners

## Plan for Success

The road from concept to a sellable product can be long and expensive if not done correctly. There are many factors that come into play and identifying the pros and cons is typically the first and best approach. We can help you weigh those factors and help decide if the product is viable.

## Stand out From Your Competition

Positively distinguishing your product or service from others will help you appear much more attractive to potential customers. You need to know who your competitors are, what they offer, their prices and understand everything you possibly can about their business, product or service. We can help place you on a level above the competition.

## Keeping Pace with Technology

Keeping up with technology requires you to allocate resources - some of which can be better used elsewhere in your business. Expertise in many technologies takes years. Instead, ATTO can be your connectivity partner and share our years of technical expertise and manufacturing capabilities. Your company can invest those saved resources in your core technology.

## Flexible and Ready to Adapt

If you are creating a solution to a business problem then being first to market is critical. ATTO is the right choice if your business excels at its core competencies yet needs assistance with network and/or storage connectivity. There's no need to waste time learning how to implement what we can provide for you right now.

## Strive for Profitability

As your supplier, ATTO allows your company to meet its financial goals. You gain access to industry-leading technology and quick transitions from design to production. We're flexible, matching your business strategies. We're a catalyst for reduced product development costs and marketplace adaptability.

## Accelerating Flash/SSD Storage Technology

### NVMe over Fabrics: The future of storage connectivity

Today's Solid State Hard Drives (SSDs) and Flash Memory have outpaced traditional protocols and connectivity methods. Designed specifically for Flash/SSD storage, NVMe reduces I/O overhead and brings various performance improvements in comparison to previous logical-device interfaces, including multiple, long command queues, and reduced latency. NVMe over Fabrics, Fibre Channel (FC-NVMe) brings these two technologies together by enabling NVMe message based commands to transfer data between a host computer and a target SSD device over a Fibre Channel network (SAN).

### Challenges:

- Delivering a minimum impact on throughput and latency
- Enabling end-to-end data integrity without impacting performance

### Featured Products:

ATTO offers high performance, reliable Fibre Channel products and solutions to improve the performance of Flash and SSD storage.

- ATTO Celerity™ 32Gb Gen 6 Fibre Channel HBAs

### Solution Benefits:

- Scalability
- Industry's lowest latency
- Improved performance
- Reliability
- Security
- Delivering lower power consumption and resulting in a lower Total Cost of Ownership

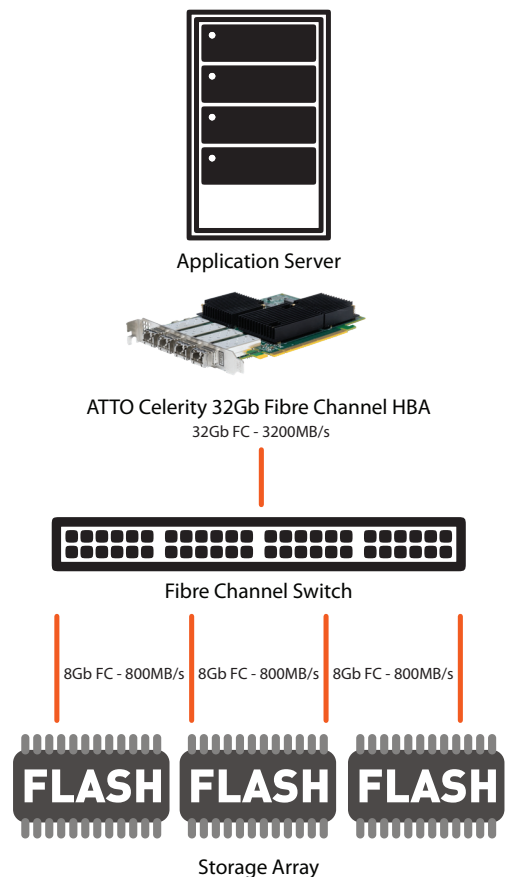

# Impress your clients with data so fast it's like they bought a time machine!

## Fibre Channel HBAs

Add ATTO Celerity™ Fibre Channel cards to workstations and servers so you can create, collaborate and move even the largest files.

## Smart Ethernet NICs

ATTO FastFrame™ 10, 25, 40, 50 and next-generation 100 Gigabit Ethernet cards deliver smooth, reliable Ethernet connectivity to workstations and servers.

## SAN Storage Controllers

ATTO XstreamCORE® Storage Controllers solve blade server storage limitations, connect SAS silos to SANS, allows storage expansion without adding more compute.

## SAS/SATA HBAs

ATTO ExpressSAS® HBAs connect to direct-attached storage for a cost-effective, high performance solution in post-production environments.

## SAS/SATA RAID

ATTO ExpressSAS® RAID adapters connect to storage arrays delivering massive performance, reliability and predictability.

## Fibre Channel Bridges

ATTO FibreBridge® products connect anything to anything, giving you unheard of flexibility and speed with storage that's easy to control.

## ATTO SiliconDisk™

ATTO SiliconDisk is a scalable, state-of-the-art RAM-based storage appliance that delivers faster performance than Flash-based SSDs and with lower latency.



## NetApp Chooses ATTO for MetroCluster™

ATTO FibreBridge® controllers are critical component in the NetApp® MetroCluster™, enabling site-to-site connectivity up to 300 kilometers apart with redundant low-latency links. The MetroCluster is used in a variety of markets including the financial, manufacturing and educational sectors to provide customers with continuous data availability for mission-critical applications.

The FibreBridge controllers, of which there are a minimum of two in each MetroCluster location, work with NetApp ONTAP® data management software to provide load balancing, failover and failback functionality.

### Challenges:

Long-distance site-to-site connectivity, resiliency, flash storage integration, ease of use.

### Featured Products:

ATTO FibreBridge® storage controller.

### Solution Benefits:

- Replication with rapid provisioning
- Downtime avoidance and disaster recovery
- Integration of multiple shelves of flash storage for MetroCluster installations
- Resilient back-end storage architecture

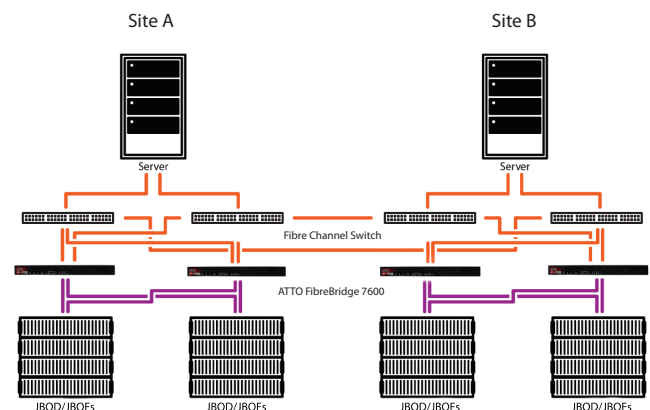

## Add Storage Expertise to your Team by Partnering with ATTO

As you develop new products and solutions, you need to be realistic about how to approach your designs. Outsourcing hardware, software, or intellectual property as you architect the design makes sense. With the right partner you save time, keep costs down and the breadth of your abilities expands.

Industry leaders choose to partner with ATTO because they know technology is in our blood, and we understand the challenges product architects face and how to tackle them.

Our engineering team becomes an extension of yours, and our nimble manufacturing capabilities can deliver what you specify, when you need it and on budget

ATTO exclusive features enhance your product, helping it to stand out against the competition, and an accelerated development cycle puts the product on the market faster.

We take pride in our history of long-lasting technology partnerships and the successes they've brought. You, too, can rely on our engineers, experience, and expertise when you need to solve a connectivity challenge.

So, when you're handed a project that requires storage or network connectivity, get ahead of the process by involving ATTO right away. As our partner, you will meet every goal on your checklist.

## ATTO Technology, Inc.

155 CrossPoint Parkway  
Amherst, New York 14068

P: +1.716.691.1999

[www.atto.com](http://www.atto.com)

